



according to
PED
Pressure Equipment Directive
97/23/EC



APPROVED BY
**BUREAU
VERITAS**

**VAPORIZZATORI GPL FEED-OUT
CE AD ACQUA ED ELETTRICI
CE HOT WATER AND ELECTRIC
FEED-OUT LPG VAPORIZERS**

SAMVAP EL-O

vaporizzatore feed-out elettrico

SAMVAP EL-O

electric feed-out vaporizer



Dati di progetto del vaporizzatore

Circuito acqua:

- Pressione di prova pneumatica: 3 bar
- Pressione di esercizio: atmosferica
- Temperatura di esercizio: - 10° C + 60° C
- Norme di progetto: VSR. M. S. - ISPESL

Circuito GPL:

- Pressione di prova idraulica: 50 bar
- Pressione di esercizio: 20 bar max
- Temperatura di esercizio: - 40° C + 120° C
- Norme di progetto: VSR. M. S. - ISPESL

Design data of the vaporizer

Shell side (water):

- Pressure of pneumatic test: 3 bar
- Working pressure: atmospheric
- Working temperature: - 10° C + 60° C
- Design standard: VSR. M. S. - ISPESL

Tube side (gas):

- Pressure of hydraulic test: 50 bar
- Working pressure: 20 bar max
- Working temperature: - 40° C + 120° C
- Design standard: VSR. M. S. - ISPESL

Caratteristiche principali dei vaporizzatori SAMVAP EL-O:

- Scatole e cablaggi elettrici Eexd (zona 1) conformi allo standard europeo EN 500014 – 500018
- Resistenze in acciaio inox, facilmente rimovibili senza smontare il vaporizzatore (mod. EL-O 100÷500), mai in diretto contatto con il GPL
- Vaso di espansione acqua del tipo aperto
- Valvola di sicurezza gas con approvazione ISPESL e TUV
- Termometro per acqua con approvazione ISPESL
- Manometro gas con valvola d'intercettazione
- Valvola a sfera in acciaio UNI PN 40 "fire safe construction" all'entrata del vaporizzatore
- Quadro elettrico a distanza IP 55 o installato sul vaporizzatore (Eexd)
- Valvola di spurgo circuito gas

Main characteristics of SAMVAP EL-O vaporizers are:

- Explosion proof electrical boxes and wirings (zone 1) according to European standards EN 500014 – 500018
- Stainless steel heating elements, quickly removable without dismantling the vaporizer (mod. EL-O 100 ÷ 500), never in direct contact with LPG
- Water expansion tank
- ISPESL and TUV approved safety valve
- ISPESL approved water thermometer
- Gas pressure gauge with valve
- Steel ball valve UNI PN 40 "fire safe construction" on gas inlet
- Remote electric panel IP 55 or Eexd electric panel mounted on the vaporizer
- Drain valve for gas circuit

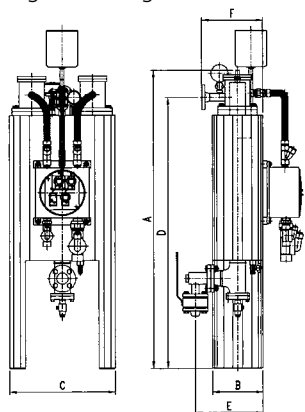

Modello 100-500 kg/h con scatola termostati
Model 100-500 kg/h with thermostats in Eexd box

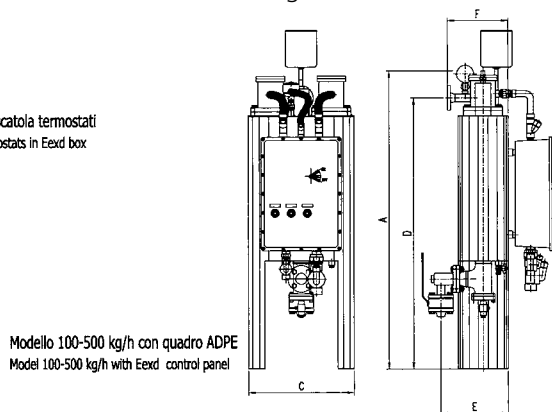

Modello 100-500 kg/h con quadro ADPE
Model 100-500 kg/h with Eexd control panel



Vaporizzatori EL-O con n° 4 termostati in scatola Eexd (abbinabile a pannelli di controllo IP 55) / EL-O vaporizers with n° 4 thermostats in Eexd box (to be combined with remote control panel IP 55)

codice/code	portata/capacity Kg./h	kW	De/gas	attacchi / gates Du/gas	A	B	C	D	E	F
VPR520250/C	25 ₍₃₀₎	4	15	25	1650	285	380	1500	534	534
VPR520500/C	50 ₍₆₀₎	8	15	25	1650	285	380	1500	534	534
VPR521000/C	100	8+8	25	25	1650	285	590	1500	380	343
VPR521500/C	150	8+16	25	25	1650	285	590	1500	380	343
VPR522000/C	200	16+16	25	32	1650	285	590	1500	380	343
VPR522500/C	250	16+24	25	32	1650	285	590	1500	380	343
VPR523000/C	300	24+24	25	32	1650	285	590	1500	380	343
VPR523500/C	350	24+32	32	32	1650	285	590	1500	380	343
VPR524000/C	400	32+32	32	40	1980	285	590	1850	590	1850
VPR525000/C	500	36+36	32	40	1980	285	590	1850	590	1850

Vaporizzatori EL-O con pannello di controllo Eexd e n° 4 termostati / EL-O vaporizers with Eexd control panel and n° 4 thermostats

codice/code	portata/capacity Kg./h	kW	De/gas	attacchi / gates Du/gas	A	B	C	D	E	F
VPR540250/C	25 ₍₃₀₎	4	15	25	1650	285	380	1500	534	534
VPR540500/C	50 ₍₆₀₎	8	15	25	1650	285	380	1500	534	534
VPR541000/C	100	8+8	25	25	1650	285	590	1500	380	343
VPR541500/C	150	8+16	25	25	1650	285	590	1500	380	343
VPR542000/C	200	16+16	25	32	1650	285	590	1500	380	343
VPR542500/C	250	16+24	25	32	1650	285	590	1500	380	343
VPR543000/C	300	24+24	25	32	1650	285	590	1500	380	343
VPR543500/C	350	24+32	32	32	1650	285	590	1500	380	343
VPR544000/C	400	32+32	32	40	1980	285	590	1850	590	1850
VPR545000/C	500	36+36	32	40	1980	285	590	1850	590	1850

※ n° 3 termostati / n° 3 thermostats

- Tutti i nostri pannelli di controllo sono forniti con dichiarazione di conformità CE / Our control panels are supplied with CE conformity certificate

SAMVAP WA-O

vaporizzatore feed-out ad acqua calda

SAMVAP WA-O

hot water feed-out vaporizer



Dati di progetto del vaporizzatore

Circuito acqua:

- Pressione di prova pneumatica: 3 bar
- Pressione di esercizio: 2 bar
- Temperatura di esercizio: - 10° C + 60° C
- Norme di progetto: VSR. M. S. - ISPESL

Circuito GPL:

- Pressione di prova idraulica: 50 bar
- Pressione di esercizio: 20 bar max
- Temperatura di esercizio: - 40° C + 120° C
- Norme di progetto: VSR. M. S. - ISPESL

Design data of the vaporizer

Shell side (water):

- Pressure of pneumatic test: 3 bar
- Working pressure: 2 bar
- Working temperature: - 10° C + 60° C
- Design standard: VSR. M. S. - ISPESL

Tube side (gas):

- Pressure of hydraulic test: 50 bar
- Working pressure: 20 bar max
- Working temperature: - 40° C + 120° C
- Design standard: VSR. M. S. - ISPESL

Caratteristiche principali vaporizzatori WA-O:

- Valvola a sfera in acciaio UNI PN 40 "fire safe construction" all'entrata del vaporizzatore
- Manometro gas con valvola d'intercettazione
- Manometro circuito acqua
- Valvola di spurgo circuito gas
- Valvola di sicurezza gas, omologata ISPESL e TUV
- Valvola di sicurezza circuito acqua, omologata ISPESL
- Flange a collarino in entrata e uscita GPL
- Termometro acqua conforme alle norme ISPESL

Main characteristics of WA-O vaporizers:

- Steel ball valve UNI PN 40 "fire safe construction" on the inlet of the vaporizer
- Pressure gauge for gas side with check valve
- Pressure gauge for shell side
- Drain valve for gas circuit
- Gas safety relief valve, ISPESL and TUV approved
- Safety relief valve for water circuit, ISPESL approved
- Welding neck flanges inlet and outlet LPG
- Water thermometer according to ISPESL standard

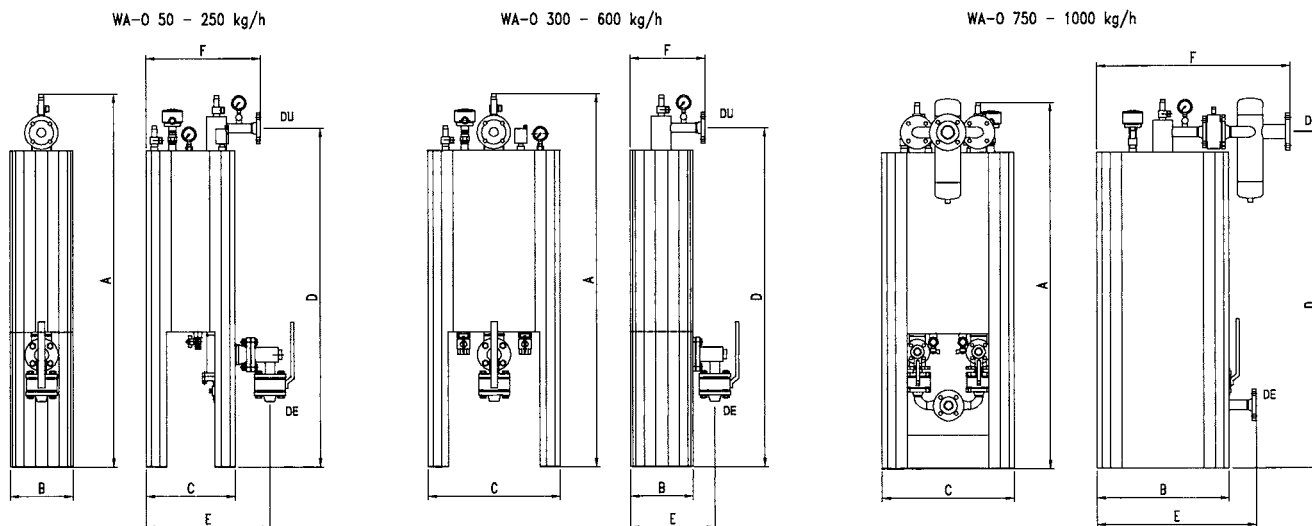

Vaporizzatori WA-O per uso industriale / WA-O vaporizers for industrial installations

codice/code	portata/capacity		attacchi / gates		dimensioni / dimension					
	Kg./h	De/gas	Du/gas	De/Du H ² O	A	B	C	D	E	F
VPR510500/C	50	25	25	25	1650	285	380	1500	534	534
VPR511000/C	100	25	25	25	1650	285	380	1500	534	534
VPR512500/C	250	25	25	25	1650	285	380	1500	534	534
VPR513000/C	300	25	32	32	1650	285	590	1500	380	343
VPR513500/C	350	32	40	32	1650	285	590	1500	380	343
VPR516000/C	600	32	40	32	1890	285	590	1850	380	343
VPR517500/C	750	32	40	32	1980	590	590	1500	712	869
VPR51010M/C	1000	32	40	32	1980	590	590	1850	712	869

Vaporizzatori WA-O per uso civile secondo UNI 10682 (*) / WA-O vaporizers for civil installations according to UNI 10682 (*)

codice/code	portata/capacity		attacchi / gates		dimensioni / dimension					
	Kg./h	De/gas	Du/gas	De/Du H ² O	A	B	C	D	E	F
VPR500500/C	50	25	25	25	1650	285	380	1500	534	534
VPR501000/C	100	25	25	25	1650	285	380	1500	534	534
VPR502500/C	250	25	25	25	1650	285	380	1500	534	534
VPR503000/C	300	25	32	32	1650	285	590	1500	380	343
VPR503500/C	350	32	40	32	1650	285	590	1500	380	343
VPR506000/C	600	32	40	32	1890	285	590	1850	380	343
VPR507500/C	750	32	40	32	1980	590	590	1500	712	869
VPR50010M/C	1000	32	40	32	1980	590	590	1850	712	869

* Completo di termostato Eexd per controllo minima temperatura e filtro DN 25 PN 40 con decantatore
 * Complete with Eexd thermostat for minimum temperature and filter DN 25 PN 40 with decanter



Disponibili centrali termiche da 30.000 a 500.000 Kcal/h
Hot Water units from 30.000 to 500.000 Kcal/h also available



fifty years of experience in gas field

ISO 9001 registered company